

High Resolution BSI Scientific CMOS

Prime BSI Express is designed on a compact platform optimized for integration and delivers the perfect balance between high resolution imaging and sensitivity with an optimized pixel design and near perfect 95% Quantum Efficiency to maximize signal detection.

A 4.2 Megapixel camera with 6.5µm pixels, it captures highly detailed images with great quality while acquiring data at high frame rates with a convenient but capable USB 3.2 Gen 2 interface. This ensures that all data is collected and no event goes undetected.

This perfect balance in performance makes the Prime BSI Express the most versatile imaging camera for system integration with:

- Highest Sensitivity
- High Resolution
- Large Field of View
- High Frame Rates
- Large Dynamic Range



- ▶ 95% Quantum Efficiency
- ▶ 6.5µm x 6.5µm Pixel Area
- ▶ 1.0e- Read Noise
- ▶ USB 3.2 Gen 2 Interface
- ▶ 78mm x 78mm x 92mm Form Factor

Features	Advantages
High Quantum Efficiency 95% Peak QE	Maximizes ability to detect weak signals, enables short exposure times at high frame rates, minimizes phototoxicity across a wide range of wavelengths
Optimized 6.5µm Pixel Size	Maximize light collection while maintaining proper spatial sampling at 60X
Extremely Low Read Noise	Maximize your ability to detect faint fluorescence
Fast Frame Rates	Capture highly dynamic events with high temporal resolution
Large Field of View	Maximize the number of cells that can be tracked and monitored per frame
Enhanced Dynamic Range	Measure both bright and dim signal levels within the same image
SMART Streaming™	Faster acquisition rates with variable exposures, ideal for multi-probed live cell imaging
Programmable Scan Mode	Easily synchronize and control acquisitions with the rolling shutter readout

4.2 Megapixel BSI CMOS Sensor



Backside Illuminated Sensor
>95% peak QE
45,000e- full well
6.5 x 6.5µm pixels
18.8mm diagonal

Easily Mounted and Secured

C-Mount
One ¼" -20 mounting holes per side

Cooling

0°C Forced Air Cooling

Advanced Triggering Capabilities

Effective Global Shutter
Four Trigger Lines:
Trigger in, Expose Out, Trigger Ready and Read Out

Convenient Interfaces

USB 3.2 Gen 2
USB Diagnostic Port for remote troubleshooting



Specifications	Camera Performance
Sensor	Gpixel GSENSE2020BSI Scientific CMOS sensor
Active Array Size	2048 x 2048 (4.2 Megapixel)
Pixel Area	6.5µm x 6.5µm (42.25µm ²)
Sensor Area	13.3mm x 13.3mm, 18.8mm diagonal
Peak QE%	>95%
Read Noise	Correlated Multi-Sampling (CMS) 1.0 e- (Median) 1.1e- (RMS)
	Combined/High Gain 1.6e- (Median) 1.8e- (RMS)
Full-Well Capacity	45,000e- (Combined Gain)
	10,000e- (High Gain)
	1,000e- (CMS)
Dynamic Range	25,000:1 (Combined Gain)
Bit Depth	16-bit (Combined Gain)
	12-bit (CMS)
	11-bit (High Gain)
Readout Mode	Rolling Shutter, Effective Global Shutter, Programmable Scan Mode
Binning	2x2 (on FPGA)

- ▶ Cameras that excel in a wide range of applications
- ▶ Flexible and customizable branding options Unique part number/ Bill of Materials (BOM)
- ▶ Bill of Materials (BOM) supports a wide range of product offerings
- ▶ Strategically located global service centers
- ▶ Dedicated support from a focused OEM team

Cooling	Sensor Temperature	Dark Current
Air Cooled	0°C @ 25°C Ambient	1.5e-/pixel/second

Specifications	Camera Interface
Digital Interface	USB 3.2 Gen 2
Lens Interface	C-Mount
Mounting Points	One ¼ 20" mounting point on each side of the camera

Programmable Scan Mode	Function
Scan Modes	Auto: Normal camera operation Line Delay: Control rolling shutter propagation rate by adding delays to the line time Scan Width: Control number of rows between reset and readout signal in the rolling shutter
Scan Direction	Down: Rolling shutter readout begins at the top of the sensor Up: Rolling shutter readout begins at the bottom of the sensor Down/Up Alternate: Rolling shutter readout alternates direction after starting at the top of the sensor

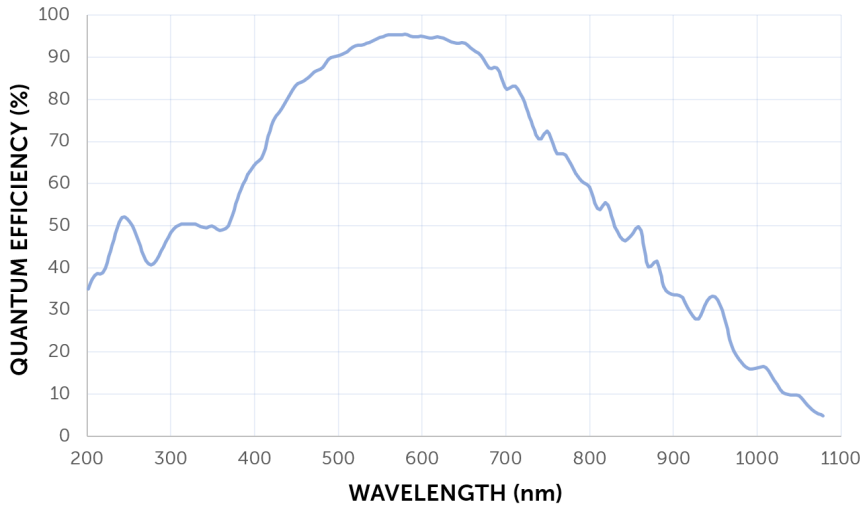

Accessories (Included)

- USB 3.2 Gen 2 Cable
- Power Supply
- Manual
- Quick Start Guide

Frame Rate

Array Size	16-bit	11-bit	12-bit (CMS)
2048x2048	43	95	43
2048x1024	87	188	87
2048x512	174	375	174
2048x256	347	745	347
2048x128	690	1468	690

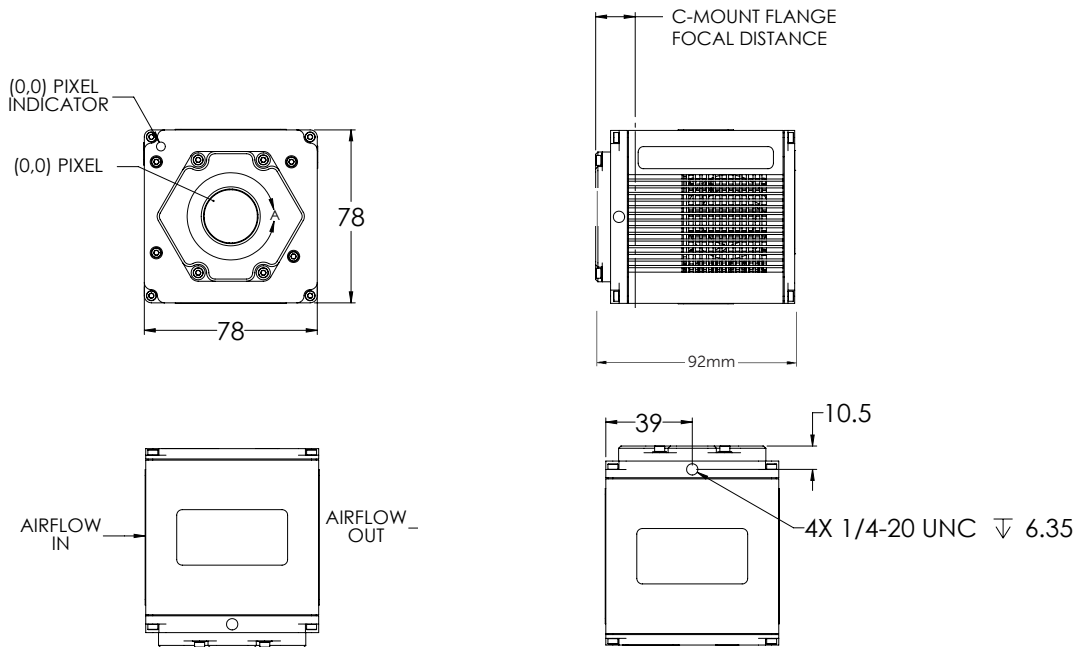

Specifications subject to change for production camera. Refer to the Teledyne Photometrics website for most current specifications.

Teledyne Photometrics is a registered trademark. Prime BSI Express is a trademark of Teledyne Photometrics. All other brand and product names are the trademarks of their respective owners.



www.photometrics.com
info@photometrics.com / tel: +1 520.889.9933

