

OLYMPUS[®]

Your Vision, Our Future

Research Inverted Microscope

IX83/IX73/IX53

IX3 Series

NEW

Built for Live Cell Imaging



EXPANDABLE TO GROW WITH YOUR RESEARCH



The fully-motorized and automated IX83 along with the semi-motorized IX73, are designed to satisfy a myriad of research needs. With additional modules providing expanded functionality, both microscopes provide the ability to enable a multitude of imaging techniques, ranging from casual documentation to long-term time-lapse imaging and other demanding cutting edge techniques.

The unique open frame on the IX83 provides ready access to the light-path making it easy to add or change modules. A variety of deck modules may be easily exchanged to add or subtract functions as needed. The IX3-ZDC module with its own specialized port is available for IX83 systems to maintain continuous focus throughout extended time-lapse use.

The IX3 system is the ideal solution for a wide range of needs, whether for improving research efficiency by recording cell dynamics across a wide area or in several locations at once, or enhancing reliability through its accurate position reproducibility and reproduction of excitation light intensity.

IX83: Two-deck System



Enables high-speed, fully automated device selection during live cell research including time-lapse imaging. Two decks offer excellent expandability.

IX83: One-deck System



An intelligent, motorized microscope that can be equipped with the IX3-ZDC to create a new standard for live cell imaging.

IX73: Two-deck System



The IX73 two-deck system combines with coded or motorized units* to realize a semi-motorized system microscope with modular expandability.

IX73: One-deck System



A microscope designed with emphasis on working efficiency for documentation, routine testing and other tasks.

IX53: One-deck System



An outstanding microscope delivering cost efficiency for brightfield and fluorescence applications.

*Except IX3-ZDC

RELIABLE HIGH RESOLUTION IMAGES THAT ARE CLEAR AND BRIGHT

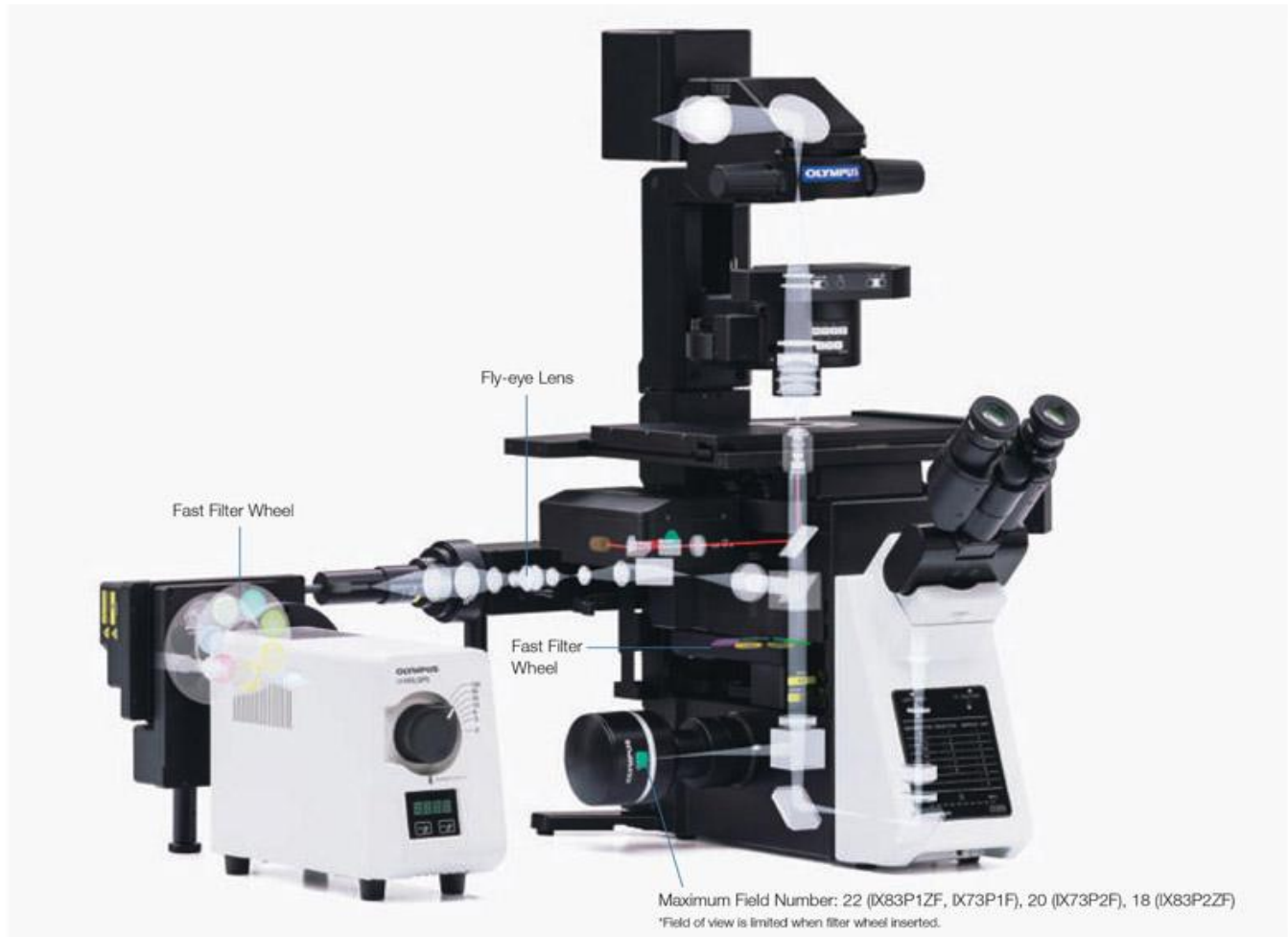

Olympus UIS2 infinity-corrected optics ensure high optical transmittance with a broad range of objectives providing wide chromatic correction and high resolution, as well as high S/N primary images regardless of the observation method. The wide field of view and fly-eye lens system provide uniform fluorescence images and enable the use of sCMOS cameras with large sensors.

Excellent Image Quality

Apochromatic Objectives Enable High Resolution Observation of Phase Contrast and Fluorescence

Phase contrast apochromatic objectives (UPLSAPO100XOPH, PLAPON60XOPH) enable high-precision observation free from optical axis displacement—even during simultaneous observation of phase contrast and fluorescence, negating the need to change the objective when switching methods.



HeLa cells

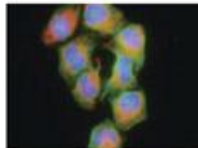

Special Objective Available for iPS/ES and Floating Cell Observation

This high-NA phase contrast objective (UCPLFLN20XPH) is especially suited for the observation of plastic dishes. It enables phase contrast observation of the cell proliferation process, for example, and delivers differentiation across a wide area in high resolution.

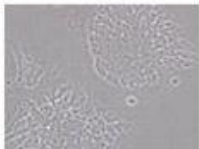

Phase contrast image of mouse ES cells

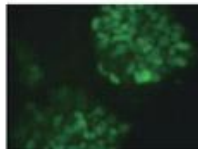

Immunofluorescence staining for Nanog



Silicone Objectives* Enable High Resolution Observation Deep Into Live Cells

Olympus offers three high-NA silicone immersion objectives: UPLSAPO30XS, UPLSAPO40XS, and UPLSAPO60XS. The refractive index of silicone oil ($n_e=1.40$) is close to that of living tissue ($n_e=1.38$), enabling high-resolution observations deep inside living tissue with minimal spherical aberration caused by refractive index mismatch. Silicone oil does not dry out or harden, so there is never a need to refill oil, making it ideal for extended time-lapse observations.

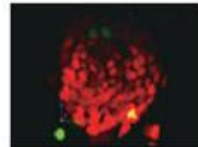

3D reconstruction images of a live sphere made of NMuMG/Fucci2 cells. Confocal images were acquired by a confocal microscope (FV1000). (Red: cell cycle G1 phase, Green: cell cycle S/G2/M phase)

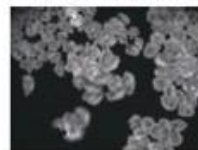

Image data courtesy of:

Asako Sakaue-Sawano, Ph.D. Atsushi Miyawaki, M.D., Ph.D.
Laboratory for Cell Function Dynamics, Advanced Technology Development Core,
RIKEN Brain Science Institute

Bright, Uniform Fluorescent Illumination

The fluorescence illuminator (IX3-RFALFE) incorporates a fly-eye lens system to provide an even distribution of fluorescence illumination, providing bright and even illumination to the entire field, including the periphery of the visual field.



With Fly-eye Lens System

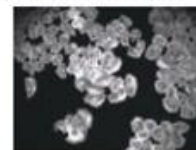

Without Fly-eye Lens System

High S/N Fluorescent Mirror Units for Efficient Detection of Fluorescent Signals

All fluorescence mirror units feature filters treated with a coating specially developed to minimize noise by absorbing more than 99% of stray light, while the sharp performance and high transmittance of the mirror units ensure efficient fluorescence signal detection.

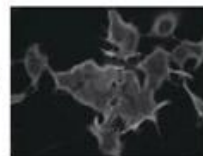
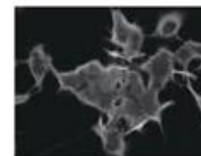

Image Captured with a Conventional FL Mirror Unit



Images Captured with New FL Mirror Units

*Use dedicated silicone oil.

INTUITIVE AND ERGONOMIC CONTROL OVER MICROSCOPE PERFORMANCE



The IX3 imaging system incorporates a range of advanced technologies to enable fine control of your imaging. As a result, it allows researchers to refine complex sequences of operations into workflows with speed and comfort, eliminating burden on the observer and minimizing cell damage.

A repositionable controller can be located comfortably close to hand, while Olympus cellSens* imaging software enables advanced control of functions. There is also an innovative, user-friendly touch panel that makes digital control simple and accurate, even when working under darkroom conditions. The Z-drift compensation system employs a near-infrared light to minimize cell damage while enabling constant focus.

The IX83 can be equipped with a multi-well compatible ultrasonic stage and the Z-drift compensation system for efficient observation and the ability to record multiple sample locations.

*cellSens software is not for clinical diagnostic use.

Smart Control

Switch Observation Methods with a Single Touch

Olympus offers a touch panel controller for the IX83, to configure all motorized and automated functions on the microscope, including advanced functions such as automatically adjusting lamp intensity according to magnification. The touch panel controller used in combination with cellSens software enables advanced customization, with the ability to program observation procedures and a range of other functions as touch panel soft keys. A hand switch is available for the IX73.



IX83 Touch Panel Controller



IX73 Hand Switch

Intuitive Microscope and XY Stage Controllers

The combination of the U-MCZ and XY-controller make it possible to provide the familiarity of conventional handle operation for confident working even in a darkroom.



Operator-friendly Design

Smooth Tracking at High Magnification

The IX3-SVR/IX3-SVL manual stages feature a smooth positioning system which enables the easy tracking of cells even in high magnifications. The user settable position limits immobilizes the stage, ensuring that the observation position is maintained during operations such as reagent application, even if the stage is inadvertently touched. It is also possible to remove 35mm dishes from the stage, place them in an incubator for culturing and return them to the stage—repositioning the exact location of the cells within the field of view.*



ZDC One-shot Function Detects Focus Fast, Even in High Magnification Observation

IX3-ZDC focus detection and tracking can be performed via the innovative touch panel independent of software. There's also a focus search function supported by a cell-safe, near-infrared laser enabling instant focusing on samples—even at high magnification.



Microscope Configuration Recall (Olympus cellSens)

The system saves microscope configurations alongside image data through incorporation of a readout function that utilizes motorized units and coded units. With this advanced system, a wide range of settings can be recalled to recreate the desired imaging conditions, thus creating an easy-to-use reproducible high-end imaging system.

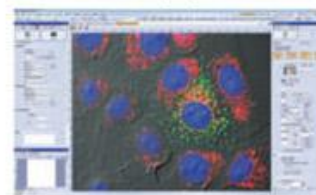

Koehler Illumination Control Via the Frontal Condenser Knob

Using a condenser lock and the front-located control knobs, the condenser can be moved and easily reset to Koehler Illumination.



Frame Construction Prevents Optical System Contamination

A catch tray under the nosepiece prevents damage to the microscope caused by contamination through spilled liquids and simplifies maintenance.



*This equipment was based on the technical development at RIKEN BSI-Olympus Collaboration Center.

IDEAL OBSERVATION AND CAPTURE OF TIME-LAPSE IMAGES

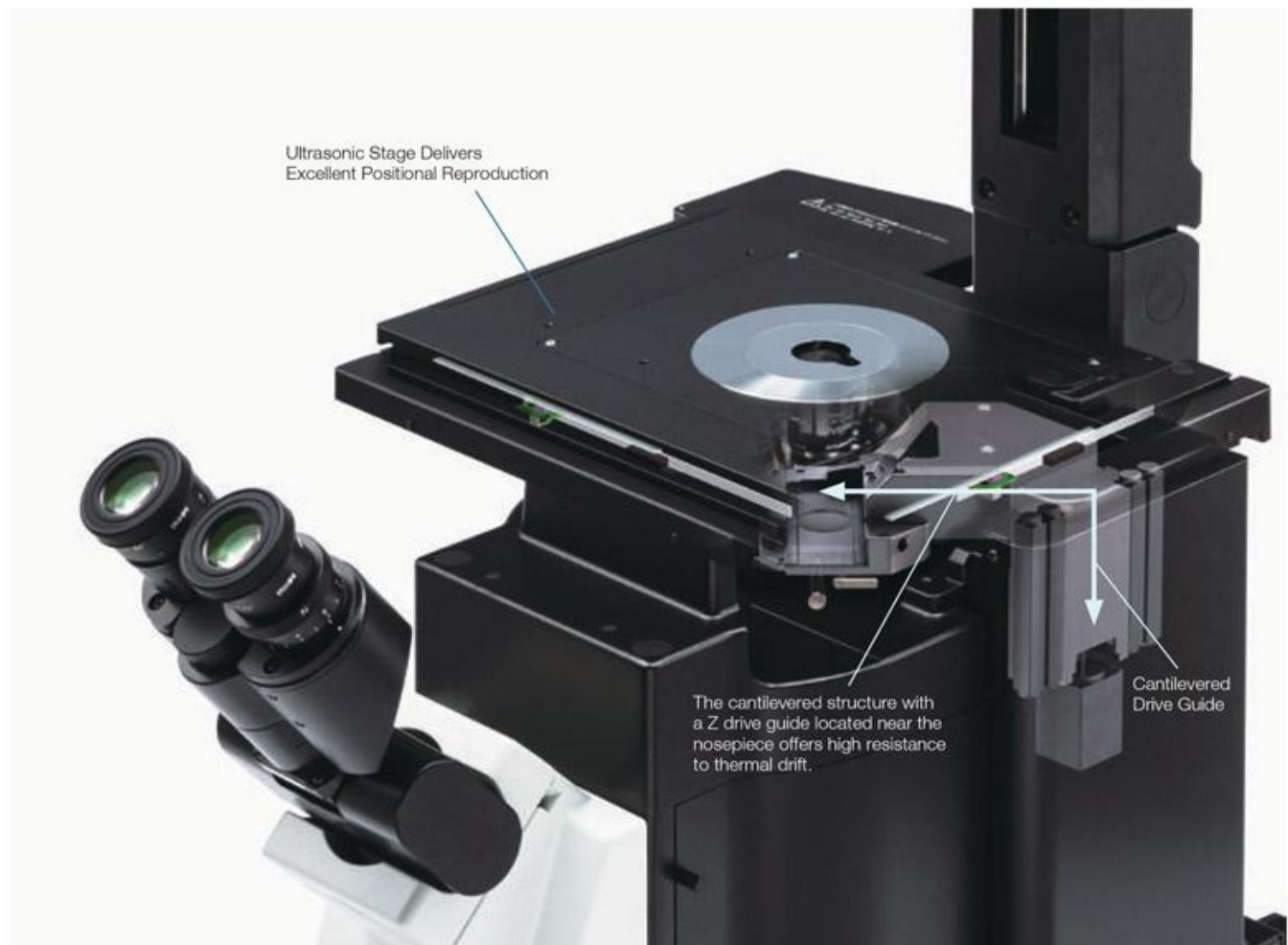

With new frame architecture and focus drive design, the IX3 system offers enhanced rigidity that reduces the impact of vibration and heat. It maintains desired positions along X, Y, and Z axes to allow reliable time-lapse imaging. The real-time Z-drift compensation system capabilities of the IX3-ZDC combine with the Olympus ultrasonic stage-capable of multipoint imaging to enable capturing of high-precision multipoint time-lapse images that are never out-of-focus or misaligned.

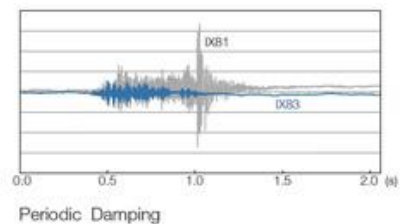
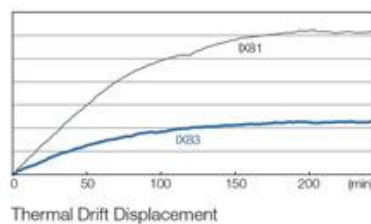
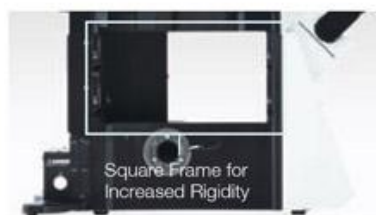

Imaging Accuracy

Z-drift Compensation System

The IX3-ZDC uses low phototoxicity IR light to detect the correct focus position as set by the user. One-shot AF mode allows several focus positions to be set as desired for deeper samples, enabling efficient Z-stack acquisition in multi-position experiments. Continuous AF mode keeps the desired plane of observation precisely in focus, avoiding focus drift due to temperature changes or the addition of reagents, making it ideal for measurements such as TIRF that requires more stringent focusing.

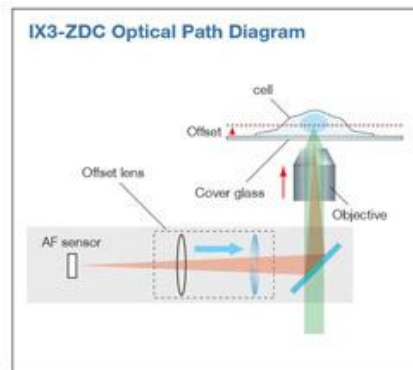

High-precision Multi-area Imaging Ultrasonic stage for IX3/IX3-SSU*

With low thermal drift and accuracy, the ultrasonic stage delivers excellent reliability for multi-area imaging. Sample holders are firmly anchored to ensure accurate positioning while the stage is in motion, so the observation position stays fixed even during high-magnification multi-point observations using slides or dishes.



IX3-SSU



IX3-HOW-2, IX3-HOS, IX3-HO35D

Time-lapse Observation Images Using ZDC

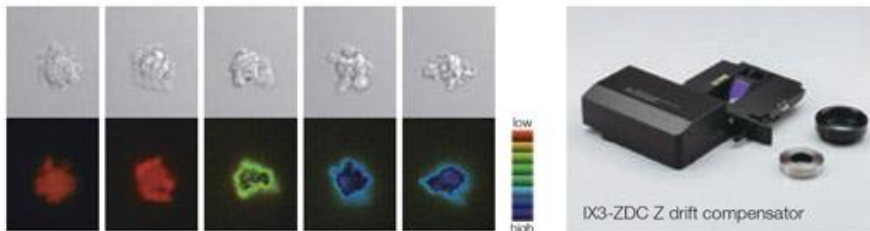

Apoptosis in cultured human ES cells, photographed at 2-minute intervals over 5 hours. (Top row: DIC imaging of physical changes; Bottom row: FRET imaging of Caspase-3 action)

Image data courtesy of:
Masatoshi Ohgushi, Ph.D., Yoshiki Sasai M.D., Ph.D., RIKEN Research Center for Developmental Biology

Reference material:
Ohgushi, M. et al. Molecular Pathway and Cell State Responsible for Dissociation-Induced Apoptosis in Human Pluripotent Stem Cells. *Cell Stem Cell* 7, 225-239(2010).

Motorized DIC Slider for IX83

Push routine brightfield and contrast studies to comfortable high performance applications like DIC in time-lapse operations or IVF for research.



High-precision Multi-area Imaging with cellSens for Enhanced Efficiency

Use the IX3 ultrasonic stage with cellSens software to conduct multi-area time-lapse imaging with greater efficiency. Image cell dynamics at multiple points within each well to obtain large amounts of data in the same experiment. Set multiple points and join adjacent fields of view to create wide area time-lapse images. The excellent position reproducibility of the ultrasonic stage used with cellSens makes it easy to obtain wide-range images with no visible joins.

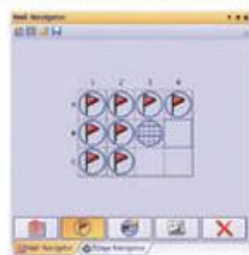

Multi-area Observation

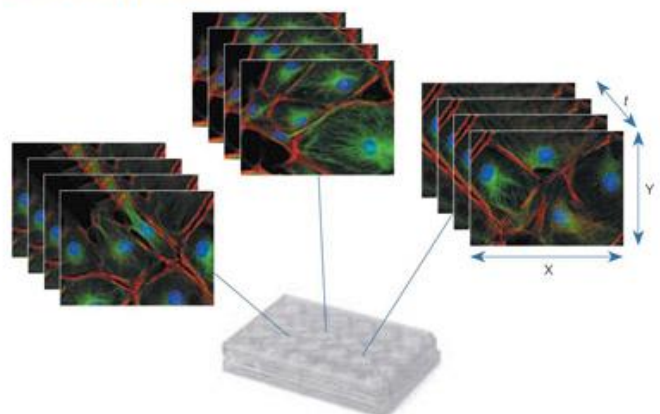

*Available in the near future.

SOPHISTICATED IMAGING OPTIONS WITH INTERCHANGEABLE OPTICAL MODULES



A diverse range of units is available for the Olympus IX3 microscope system, bringing greater efficiency to everything from casual observation to serious imaging. Simple cassette-like insertion into the deck makes it easy to mount fluorescence mirror turrets, a right side port with C-mount, an encoded magnification changer, reflected light fluorescence illuminators and other desired units. The large open frame allows fitting a motorized emission filter wheel with the infinity space of the microscope. This eliminates image shift between channels and allows the eyepieces to see what the camera sees. An automated or manual Right Side Port deck module provides camera mounting flexibility.

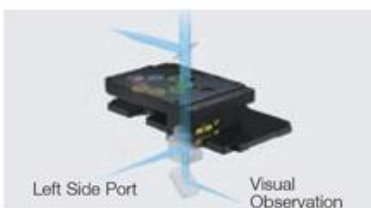

Deck Units/High Speed Units

Motorized Fluorescence Mirror Turret (IX3-RFACA)

An automated vibration-free turret fitted with 8 mirror units delivers smooth, fast switching. Mirror units can be used with 25mm diameter filters or 32mm diameter filters. No tool use is required to change mirror units, which are easily installed or removed in seconds.



IX3-RFACA

Motorized Right Side Port with C-mount (IX3-RSPCA)/ Manual Right Side Port with C-mount (IX3-RSPC)

Right side ports with a C-mount allow the light-path switching component to be fitted with up to two mirror units, enabling the construction of customized systems for applications such as split imaging.



IX3-RSPCA

Coded Intermediate Magnification Changer (IX3-CAS)

Magnification can be changed between 1x, 1.6x and 2x by smooth lever operation. Since the system incorporates coded functionality, information on intermediate magnifications is saved with image data.



IX3-CAS

Motorized Fast Filter Wheels and Shutters

Filter wheels can switch between filters in just 60 milliseconds, while shutters can open and close in just 26 milliseconds. The IX83 is capable of controlling up to six filter wheels and four shutters to satisfy complex multi-modal imaging.



U-FFWEM



U-FFW



U-FSHU

Fluorescence System

Reflected Light Fluorescence Illuminators

An L-shaped fluorescence illuminator with a fly-eye lens system provides bright, consistent illumination without adjustment, an L-shape-fluorescence illuminator is equipped with a field iris diaphragm and aperture iris diaphragm, and a straight-through fluorescence illuminator is available for applications demanding intense excitation light. A wide range of light sources are available, including light guide light sources and lamp houses compatible with both 100W mercury and 75W xenon illumination.



- ① U-LH100HG
- ② U-LH75XEAP0
- ③ U-LH100HGAPO
- ④ U-HGLGPS
- ⑤ IX3-RFA
- ⑥ U-LLGAD
- ⑦ IX3-RFAL
- ⑧ IX3-RFALFE

130W Mercury Lamp Housing with Fiber (U-HGLGPS)

Fluorescent light source offering long life and maintenance-free operation. Delivers bright, even illumination and requires no centering adjustment. A liquid light guide ensures that extended observations can be carried out without concern regarding heat transfer to samples.



Motorized Units/Coded Units

A Cost-efficient Way to Upgrade to a Motorized Microscope

A wide range of motorized and encoded units are available, including an 8-position motorized fluorescent mirror turret, an encoded fluorescence mirror turret, a motorized 6-position nosepiece, an encoded 6-position nosepiece, a motorized long working distance universal condenser, filter wheels and shutters.



- ① IX3-LWUCDA
- ② IX3-MLWCDA
- ③ U-FFWEM
- ④ U-FFW
- ⑤ U-FSHU
- ⑥ IX3-RFACA
- ⑦ IX3-RFCS
- ⑧ IX3-RSPCA
- ⑨ IX3-D6RES
- ⑩ IX3-D6REA
- ⑪ IX3-DICTA

DELIVERING A RANGE OF SOLUTIONS FOR PRECISE REPRODUCTION OF EXPERIMENTS



Olympus cellSens* imaging software streamlines the process from observation to image analysis and data management, in complex imaging systems that combine multiple methods of observation.

The software offers advanced compatibility with the IX3 system to easily control the positions of the ultrasonic stage and Z-drift compensation system, and perform other operations such as time-lapse control, DSU disk IN/OUT function to switch between confocal and regular observations, incident angle adjustment in cell[^]TIRF, and switching between cell[^]TIRF and DSU.

When the software is started, the observation method set by the software can be controlled by touch panel, manual controller, or hand switch in addition to control from the computer screen.

The software can record microscope conditions when performing an experiment, so that users can easily reproduce the same experiment at a later point in time.

*cellSens software is not for clinical diagnostic use.

Olympus cellSens Imaging Software

Olympus cellSens imaging software is available in three packages to meet individual workflow needs. "Entry" is used for simple image acquisition. "Standard" provides simple operation for imaging documentation and "Dimension" allows control of the complete workflow from image capture to analysis.

Imaging

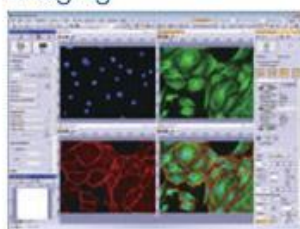

Capture multi-color, time lapse, and z-stack images with ease. Just select the appropriate capture button, add relevant parameters, and click "Start". The Process Manager makes it easy for experts and beginners to capture multidimensional image.

Processing

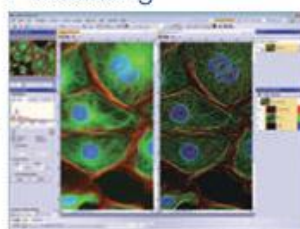

Automatically view your data in the colors and layout you choose. Take advantage of an array of professional image processing functions, such as stitching, extended focus, deconvolution, and unmixing.

Analyzing

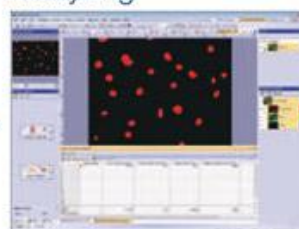

Make measurements using an intuitive interface. cellSens offers region of interest, phase analysis, and cell count capability. Export raw measurement data to an MS Excel or cellSens workbook format with a single click.

Reporting



Actively collaborate with colleagues and coworkers with special tools including Database, and Reporting functions. These functions make it simple to manage, share, and distribute your own image and data reports.

Dark Interface Skin

The Dark interface skin lets cellSens adapt to sensitive environments: icons are however still colored for easy recognition and quick selection.

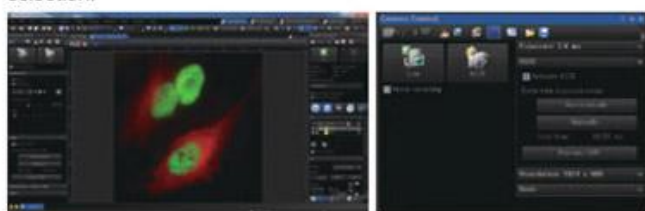

Dark Interface Skin

Well Plate Navigator

The Well Plate Navigator allows to automatically scan and acquire images from different plate formats, either standard or customized. All acquired images can be saved into a structured database for easy access, together with their well position and user comments. The tight integration with Olympus IX3-ZDC Z drift compensator guarantees well focused images, regardless of the plate positioning.



Deconvolution

This useful feature eliminates blur from single plane images. Processing can be carried out multiple times and the results can be adjusted while viewing them on the screen. A 3D deconvolution module is also available for use on multi-plane images.

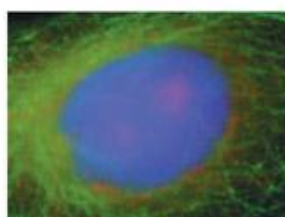

Original Image

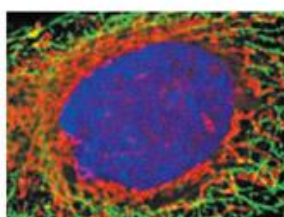

Deconvolved Image

Image Stitching

The manual multiple image alignment composes a single montage image as you traverse the specimen. Multiple saved images with adjoining components can also be combined into a single free-shape image. Panoramic imaging can be completely automated when Dimension and its optional multiposition function integrated into a motorized microscope.

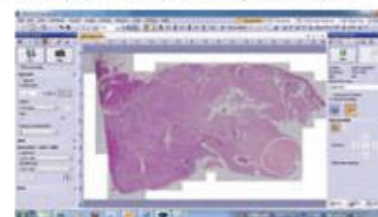

SYSTEM DESCRIPTION

DSU Spinning Disk Confocal System

Real-time Cell Imaging with Excellent Sectioning Disk Scanning Unit for IX83

Enables real-time confocal observation of images with excellent sectioning. Fits to the left side camera port instead of the light source illumination port, allowing for simultaneous attachment with other units.

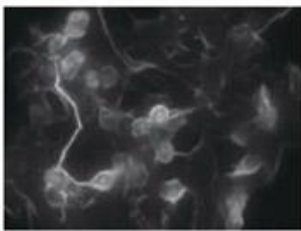

Widefield Fluorescence Image

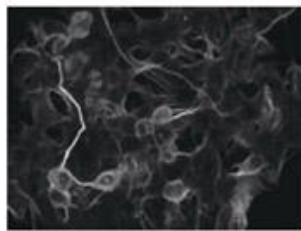

DSU Image



Principles of Slit-disk Optical System

An optical disk with reticular slits, called a slit disk, is placed in a conjugate position to the target focal point, and excitation light is illuminated on the sample through. The signal emitted by the sample is returned through these slits to a high-sensitivity camera. Since only light from the focal plane of the sample can pass through the slits, the process removes out of focus information from in front of and behind the focal plane. The rapidly spinning disk eliminates out-of-focus light from the entire range of the image.

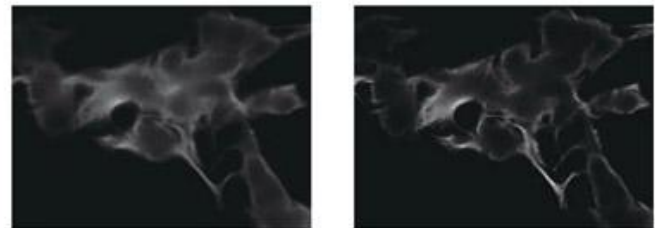
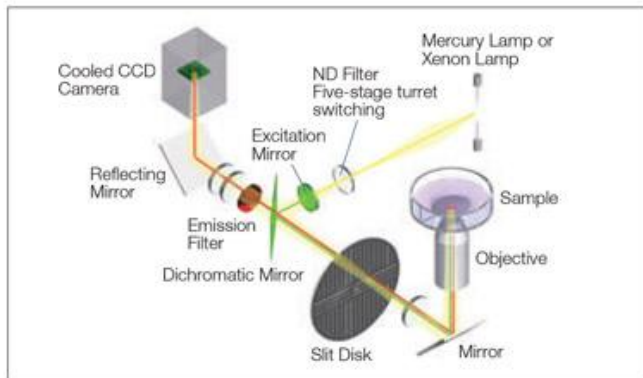

Widefield Fluorescence Image

DSU Image

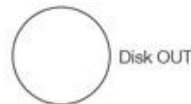

Disk OUT



Rapidly spinning disk

Features high-output liquid light guide illumination and a fluorescence mirror unit with a high S/N ratio providing images with bright fluorescence and minimal noise.



Conventional Image

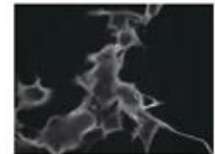

DSU Images

DSU Specifications

Optical System	<ul style="list-style-type: none"> •FN: 11 (only for camera observation) •FS (PUSH / PULL system, equipped with centering mechanism) •Projection Magnification of Field Stop : 1 •Imaging Magnification : 1 •Supported Observation Methods 1) Confocal Observation 2) Widefield Observation 3) Transmitted Observation (BF, PH, DIC)
Shutter	<ul style="list-style-type: none"> •Manual shutter : 1 (PUSH / PULL system) •Motorized shutter : 1 [Use No.6 (light shielding) position of ND filter wheel]
Confocal Disk	<ul style="list-style-type: none"> •Slit type confocal disk •Selectable disk (Provided with standard DSU-D2) •Motorized light path IN / OUT.
Mirror Unit Cassette	<ul style="list-style-type: none"> •Mirror units can be selected by the motorized turret. •Number of attachable mirror units : 6 pieces (Provided with standard DSU-MGFP and U-MRFPHQ)
ND Filter Wheel	<ul style="list-style-type: none"> •ND filters are selected by the motorized turret. •ND filter assignment No.1 : Idle hole No.2 : ND50 No.3 : ND25 No.4 : ND6 No.5 : ND1.5 No.6 : Light shielding plate (shutter position)
Attaching Camera	C mount (1-32UNF)
Software	cellSens (Operates and controls IX3-DSU, IX83F and motorized parts of other motorized units)
Attachable microscope	Left side port of IX83P1ZF and IX83P2ZF

cell[^]TIRF System

Simultaneous Quad-wavelength TIRF Acquisition Automated TIRF System/cell[^]TIRF*

Motorized control of the laser angle of incidence enables optimal adjustment of the penetration depth independently for each wavelength, using only a mouse click. Four lasers, spanning from 405nm to 640nm may be connected allowing the simultaneous capture of four separate wavelengths, enabling seamless switching between multicolor TIRF imaging and widefield fluorescence. The primary laser path is equipped with a point FRAP optical system that can also be used for kinetic measurements such as molecular diffusion, bonding, and velocity determination. Combination systems can also be assembled combining cell[^]TIRF with the IX3-DSU."

cell[^]TIRF is a Class 3B laser product. Avoid direct eye exposure.



*Available in the near future

NA 1.7 TIRF Objective

The NA 1.7 APON100XHOTIRF* objective expands adjustable range for production of evanescent fields enabling the user to form thin evanescent fields by simply adjusting the angle of incidence. High NA objectives for TIRF from 60x to 150x are also available.

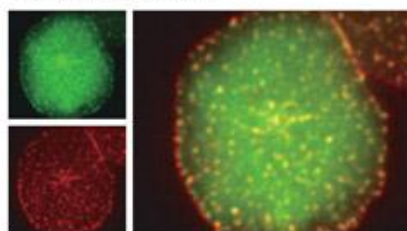

Image data courtesy of:
Akiko Hashimoto-Tane,
Ph.D.
Takashi Saito, Ph.D.
Laboratory for Cell Signaling,
RIKEN Research Center for
Allergy and Immunology

Colocalization of the Dynein Complex with
T Cell Receptor Microclusters

Reference material:

Akiko Hashimoto-Tane, Takashi Saito, *et al.* (2011). Dynein-Driven Transport of T Cell Receptor Microclusters Regulates Immune Synapse Formation and T Cell Activation. *Immunity* 34, 919-931.

•Upper images acquired by IX81.

TIRF Image Acquisition with High Resolution and a High Frame Rate

TIRF observation demands more accurate focusing. To meet this demand, the IX83 two-deck system can be combined with the IX3-ZDC to deliver live imaging at a high frame rate, while maintaining accurate real-time focus.

FLUOVIEW System

Simultaneous Photostimulation during Imaging Biological Confocal Laser Scanning Microscope/FV1200

The FLUOVIEW FV1200 imaging scanner can be configured with a dedicated SIM scanner and GaAsP ultra-high-sensitivity detector, along with cell dispersion package and time-lapse imaging unit to construct an ideal confocal laser scanning microscope system achieving multi-dimensional observation, stimulation, and measurement.

FV1200 is a Class 3B laser product. Avoid direct eye exposure.



Image data "Drosophila, Stage 14" courtesy of:
Dr. Tetsuya Kojima, Laboratory of Innovational Biology, Department of Integrated
Biosciences Graduate School of Frontier Sciences, University of Tokyo

SYSTEM DESCRIPTION

Motorized Middle Long Working Distance Condenser/ IX3-MLWCDA

The IX3-MLWCDA supports brightfield, DIC, relief-contrast, and polarizing observations and up to four optical elements of the turret, with motorized switching of the slider polarizer. The condenser is useful for sperm selection and spindle observation of oocytes, and offers motorized adjustment for spindle observation with optimum contrast. A long working distance and slim design makes injection easy.



IX3-MLWCDA

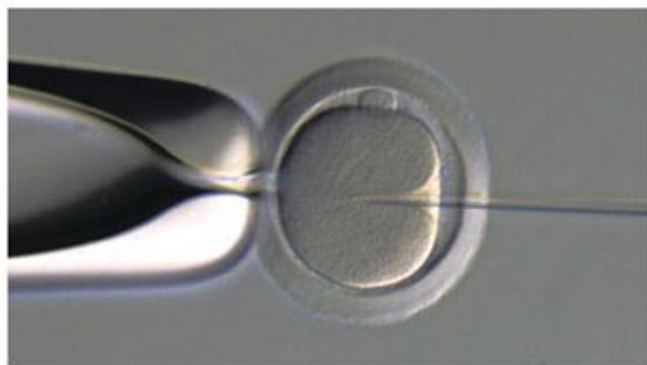

Embryo of Rat

Maintain Cell Viability Over an Extended Period of Time

Stage-top, or microscope enclosure style temperature/CO₂ incubators are easily configured with IX3 systems. Incubation enables the maintenance of living cell activity and allows for reliable time-lapse observation for up to several days.

(Available in the near future)



Measuring Excitation Light Intensity for High Reproducibility in Imaging Adapter for Excitation Irradiance Meter/IX3-EXMAD*

Olympus now offers an adapter for a power meter that can directly measure the excitation light intensity per unit surface area of the sample, as well as offering irradiance display software. Displays the measurement results on a monitor and records the data, eliminating the need for laborious calculations. This makes it possible to check the excitation light intensity before starting an experiment, enhancing the reliability of experiments. Data can also be easily shared.

*This equipment was based on the technical development at RIKEN BSI-Olympus Collaboration Center.



Objective specifications

UIS2 objective		NA	W.D. (mm)	FN	Cover glass thickness (mm)	Immersion	Spring	Correction ring	Iris diaphragm	Water proof & oil proof function
UPLSAPO	UPLSAPO 4X	0.16	13	26.5	—					
	UPLSAPO 10X2	0.40	3.1	26.5	0.17					
	UPLSAPO 20X	0.75	0.6	26.5	0.17		✓			
	UPLSAPO 20X0	0.85	0.17	26.5	—	Oil	✓			✓
	UPLSAPO 30XS	1.05	0.8	22	0.13–0.19	Silicone		✓		✓
	UPLSAPO 40X2	0.95	0.18	26.5	0.11–0.23		✓	✓		
	UPLSAPO 40XS	1.25	0.3	22	0.13–0.19	Silicone	✓	✓		✓
	UPLSAPO 60XW	1.20	0.28	26.5	0.13–0.21	Water	✓	✓		✓
	UPLSAPO 60X0	1.35	0.15	26.5	0.17	Oil	✓			✓
	UPLSAPO 60XS	1.30	0.3	22	0.15–0.19	Silicone	✓	✓	✓	✓
	UPLSAPO 100X0	1.40	0.13	26.5	0.17	Oil	✓			✓
	UPLSAPO 100XOPH	1.40	0.13	26.5	0.17	Oil	✓			✓
PLAPON	PLAPON 60X0	1.42	0.15	26.5	0.17	Oil	✓			✓
	PLAPON 60XOSC2	1.40	0.12	22	0.17	Oil	✓			✓
	PLAPON 60XOPH	1.42	0.15	26.5	0.17	Oil	✓			✓
UPLFLN	UPLFLN 4X	0.13	17	26.5	—					
	UPLFLN 10X2	0.30	10	26.5	—					
	UPLFLN 20X	0.50	2.1	26.5	0.17		✓			
	UPLFLN 40X	0.75	0.51	26.5	0.17		✓			
	UPLFLN 40X0	1.30	0.2	26.5	0.17	Oil	✓			✓
	UPLFLN 60X	0.90	0.2	26.5	0.11–0.23		✓	✓		
	UPLFLN 60X0I	1.25–0.65	0.12	26.5	0.17	Oil	✓		✓	✓
	UPLFLN 100X02	1.30	0.2	26.5	0.17	Oil	✓			✓
UPLFLN 100X0I2	1.3–0.6	0.2	26.5	0.17	Oil	✓		✓	✓	
PLFLN	PLFLN 100X	0.95	0.2	26.5	0.14–0.2		✓	✓		
UCPLFLN	UCPLFLN 20X	0.7	0.8–1.8	22	0–1.6			✓		
	UCPLFLN 20XPH	0.7	0.8–1.8	22	0–1.6			✓		
LUCPLFLN	LUCPLFLN 20X	0.45	6.6–7.8	22	0–2			✓		
	LUCPLFLN 40X	0.60	2.7–4	22	0–2			✓		
	LUCPLFLN 60X	0.70	1.5–2.2	22	0.1–1.3			✓		
	LUCPLFLN 20XPH	0.45	6.6–7.8	22	0–2			✓		
	LUCPLFLN 20XRC	0.45	6.6–7.8	22	0–2			✓		
	LUCPLFLN 40XPH	0.60	3.0–4.2	22	0–2			✓		
	LUCPLFLN 40XRC	0.60	3.0–4.2	22	0–2			✓		
	LUCPLFLN 60XPH	0.70	1.5–2.2	22	0.1–1.3			✓		
UPLFLN-PH	UPLFLN 4XPH	0.13	17	26.5	—					
	UPLFLN 10X2PH	0.30	10	26.5	—					
	UPLFLN 20XPH	0.50	2.1	26.5	0.17		✓			
	UPLFLN 40XPH	0.75	0.51	26.5	0.17		✓			
	UPLFLN 60X0IPH	1.25–0.65	0.12	26.5	0.17	Oil	✓			✓
	UPLFLN 100X02PH	1.30	0.2	26.5	0.17	Oil	✓			✓
UPLFLN-PHP	UPLFLN 4XPHP	0.13	16.4	22	—					
CPLFLN	CPLFLN 10XPH	0.30	9.5	22	1					
	CPLFLN 10XRC	0.30	9	22	1.5					
LCACHN	LCACHN 20XPH	0.40	3.2	22	1					
	LCACHN 20XPHP	0.40	3.2	22	1					
	LCACHN 20XRC	0.40	2.8	22	1.5					
	LCACHN 40XPH	0.55	2.2	22	1					
	LCACHN 40XPHP	0.55	2.2	22	1					
	LCACHN 40XRC	0.55	1.9	22	1.5					
CACHN & CPLN	CACHN 10XPHP	0.25	8.8	22	—					
	CPLN 10XPH	0.25	10	22	1					
	CPLN 10XRC	0.25	9.7	22	1.5					
UAPON 340	UAPON 20XW340	0.70	0.35	22	0.17	Water	✓			✓
	UAPON 40X0340-2	1.35	0.1	22	0.17	Oil	✓			✓
	UAPON 40XW340	1.15	0.25	22	0.13–0.25	Water	✓	✓		✓
TIRF	APON 60X0TIRF	1.49	0.1	22	0.13–0.19	Oil		✓		✓
	APON 100X0TIRF*	1.70	0.08	22	0.15	Oil		✓		✓
	UAPON 100X0TIRF	1.49	0.1	22	0.13–0.19	Oil		✓		✓
	UAPON 150X0TIRF	1.45	0.08	22	0.13–0.19	Oil		✓		✓

*HIGHINDEX-CG cover glass and dedicated immersion oil required.

IX83/IX73 system diagram

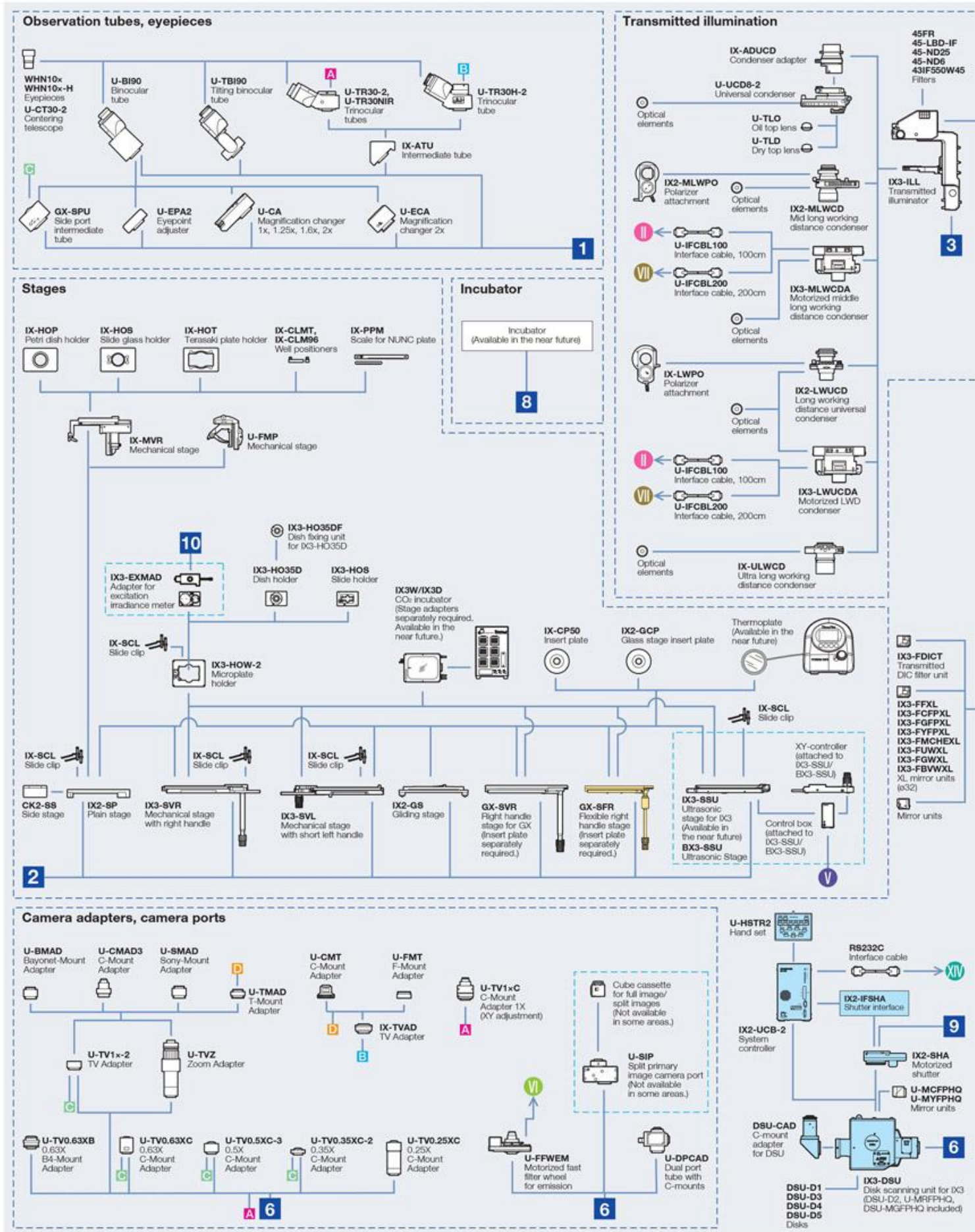

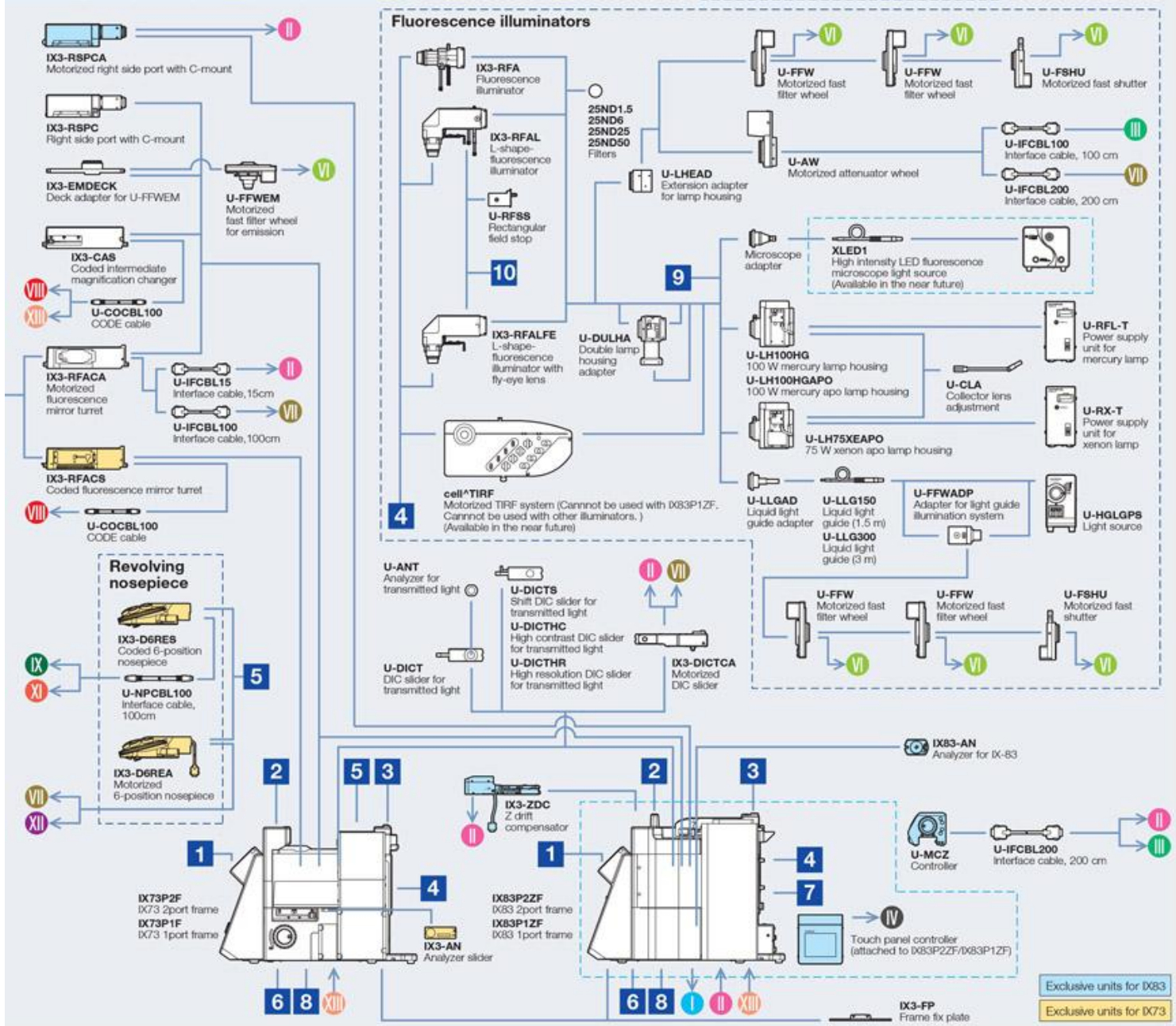
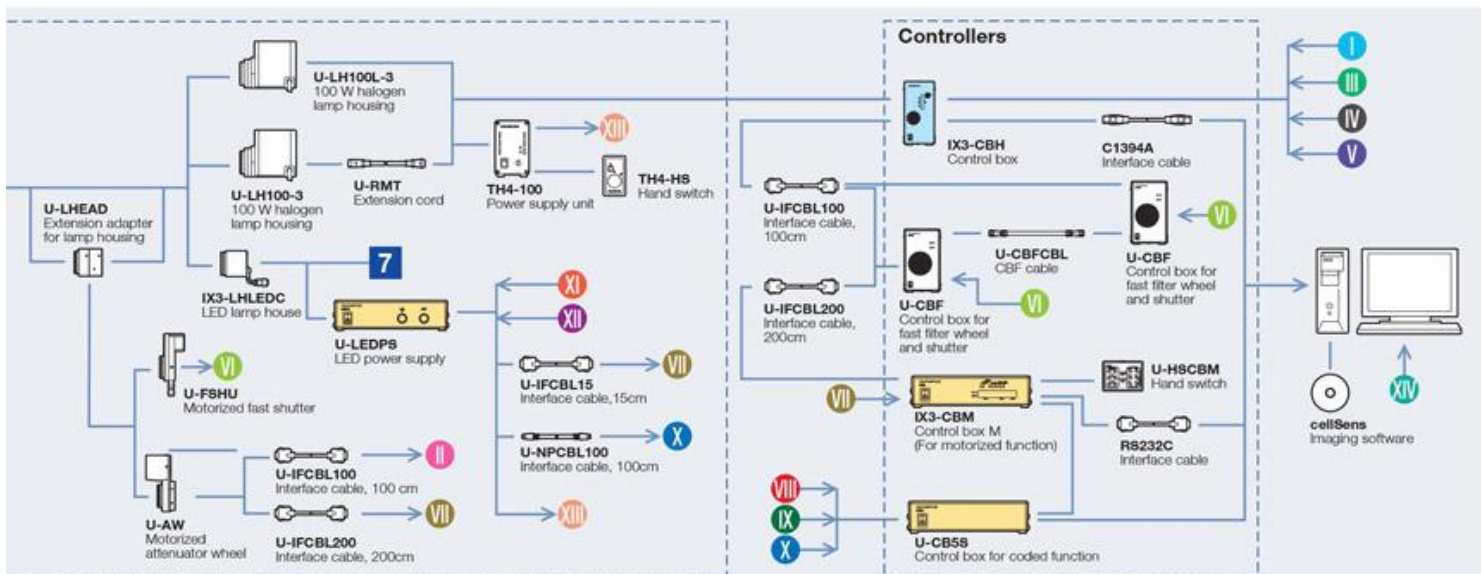

IX53 system diagram

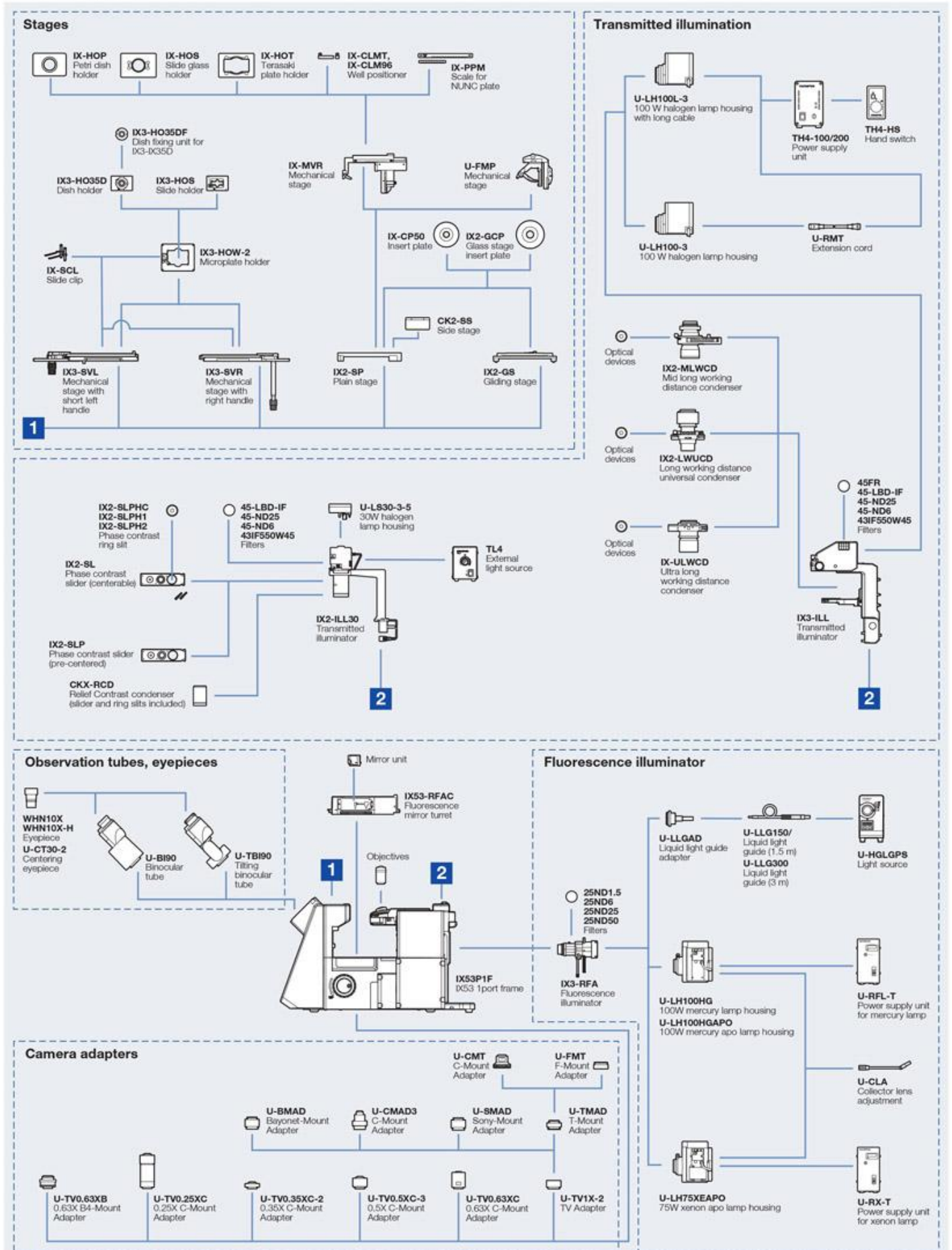

IX3 specifications

		IX83	IX73	IX53
Microscope frame	Optical system	UIS2 optical system		
	Revolving nosepiece	<ul style="list-style-type: none"> Motorized sextuple revolving nosepiece (DIC slider attachable), simple waterproof structure 	<ul style="list-style-type: none"> Motorized sextuple revolving nosepiece (DIC slider attachable), simple waterproof structure Coded sextuple revolving nosepiece (DIC slider attachable), simple waterproof structure 	<ul style="list-style-type: none"> Sextuple revolving nosepiece, simple waterproof structure
	Focus	Stroke: 10.5mm Minimum increment: 0.01μm, Maximum nosepiece movement speed: 3mm/s	Stroke: 10mm	Stroke: 10mm
	Light path selection	Motorized 0:100/50:50/100:0 (Left side port: BI port)	0:100/50:50/100:0 (Left side port: BI port)	50:50 (Left side port: BI port)
Transmitted light illuminator	Pillar tilt mechanism (30° inclination angle, with vibration reducing mechanism), Condenser holder (with with 88mm stroke, refocusing mechanism), Field iris diaphragm adjustable, 4 filter holders Light source: •12V 100W halogen bulb (pre-centered) • High color reproductive LED light source			<ul style="list-style-type: none"> •30W halogen illuminator: Detachable condenser lens system (NA 0.3, W.D. 72mm), single filter holder aperture iris diaphragm adjustable •100W halogen illuminator: Pillar tilt mechanism (30° inclination angle, with vibration reducing mechanism), Condenser holder (with 88mm stroke, refocusing mechanism) Field iris diaphragm adjustable, 4 filter holders
Observation tube	Widefield (FN 22)	•Widefield tilting binocular •Widefield binocular •Widefield trinocular		•Widefield tilting binocular •Widefield binocular
Stage	Scanning stage with ultrasonic	IX3-SSU: Stage stroke: X: 114mm x Y: 75mm, maximum stage movement speed: 20mm/s BX3-SSU: Stage stroke: X: 76mm x Y: 52mm, maximum stage movement speed: 30mm/s		—
	Mechanical stage with right handle	Stage stroke: X: 114mm x Y: 75mm, stage position locking function		
	Right handle stage	Stage stroke: X: 50mm x Y: 50mm		—
	Flexible right handle stage	—	Stage stroke: X: 50mm x Y: 50mm	—
	Gliding stage	Upper circular stage 360° rotatable, 20mm (X/Y) travel		
	Plain stage	232mm (X) x 240mm (Y) stage size, stage insert plate exchangeable (ø110mm)		
Condenser	Motorized long working distance condenser	W.D. 27mm, NA 0.55, motorized turret with 7 position slots for optical devices (3 positions for ø30mm and 4 positions for ø38mm), motorized aperture and polarizer		—
	Motorized middle long working distance condenser	NA 0.5, W.D. 45mm, 4 positions for optical devices (for ø50mm, Relief Contrast optical devices rotatable)		—
	Long working distance universal condenser	NA 0.55, W.D. 27mm 5 positions for optical devices (3 positions for ø30mm and 2 position for ø38mm)		—
	Mid long working distance relief contrast	NA 0.5, W.D. 45mm, 4 positions for optical devices (for ø50mm, Relief Contrast optical devices rotatable)		—
	Ultra long working distance	NA 0.3, W.D. 73.3mm, 4 positions for optical devices (for ø29mm)		—
Fluorescence illuminator	L-shape-fluorescence illuminator with flyeye lens	L-shaped design with exchangeable FS module		—
	L-shape-fluorescence illuminator	L-shaped design with exchangeable FS and AS modules		—
	Fluorescence illuminator	Straight design with field iris diaphragm		—
Fluorescence mirror turret	Motorized fluorescence mirror turret	Motorized turret with 8 positions, built-in shutter, simple waterproof structure		—
	Coded fluorescence mirror turret	—	Coded 8 positions turret, built-in shutter, simple waterproof structure	—
	Fluorescence mirror turret	—	—	Turret with 8 positions, built-in shutter, simple waterproof structure
Fluorescence light source	•130W Hg light guide illumination •100W Hg apo lamp housing and transformer •100W Hg lamp housing and transformer •75W Xe lamp housing and transformer			
Focus compensator	Z drift compensator	Offset method (Focus search, one-shot focus, continuous focus), Class 1 laser product	—	
Filter wheel/shutter	Motorized fast filter wheel	High speed mode 60ms, Low vibration mode 100ms (rotation time until next hole on the wheel)		—
	Motorized fast filter wheel for emission	High speed mode 60ms, Low vibration mode 100ms (rotation time until next hole on the wheel) C-mount adapter and bayonet mount adapter are enclosed		—
	Motorized fast shutter	High speed mode 26.2ms, Low vibration mode 60ms (rotation time on one way)		—
	Motorized attenuator wheel	Time to shift another filter 300ms (rotation time until next hole on the wheel)		—
Operating environment	<ul style="list-style-type: none"> • Indoor use • Ambient temperature: 5 °to 40°C (41° to 104°F) • Maximum relative humidity: 80% for temperatures up to 31°C (88°F), decreasing linearly through 70% at 34°C (93°F), 60% at 37°C (99°F), to 50% relative humidity at 40°C (104°F) • Supply voltage fluctuations: Not to exceed ±10% of the normal voltage 			

Motorized or coded units are designed for the IX3 series use in industrial environments for the EMC performance (IEC61326-1 Class A device). Using it in a residential environment may effect other equipment in the environment.

Dimensions

(Unit : mm)

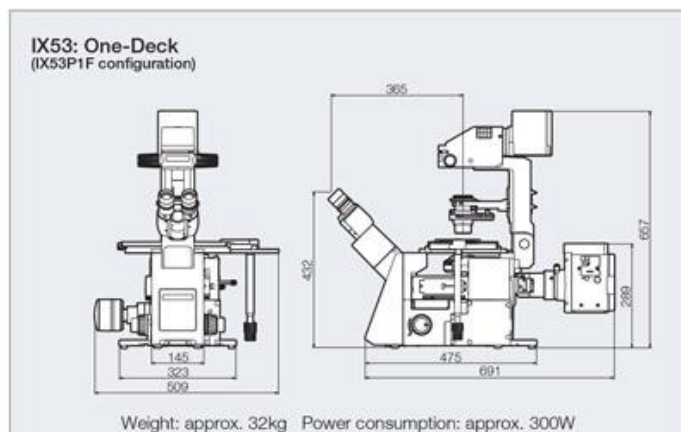
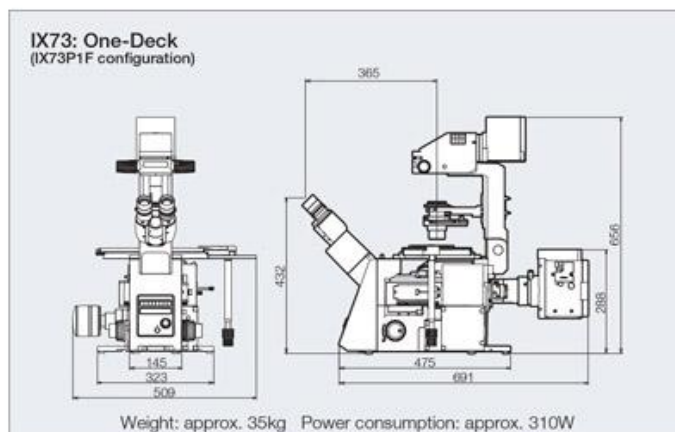
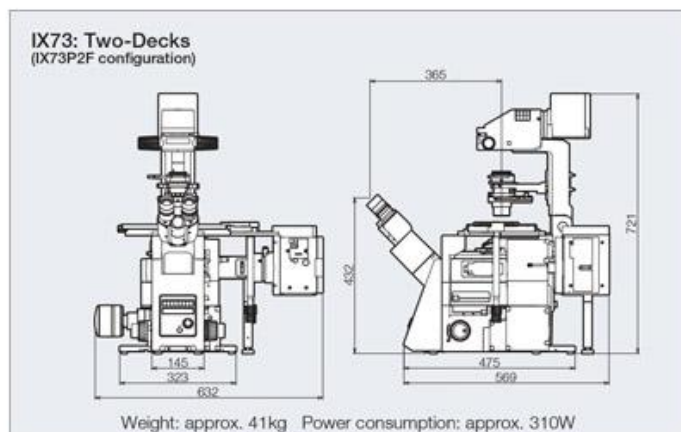
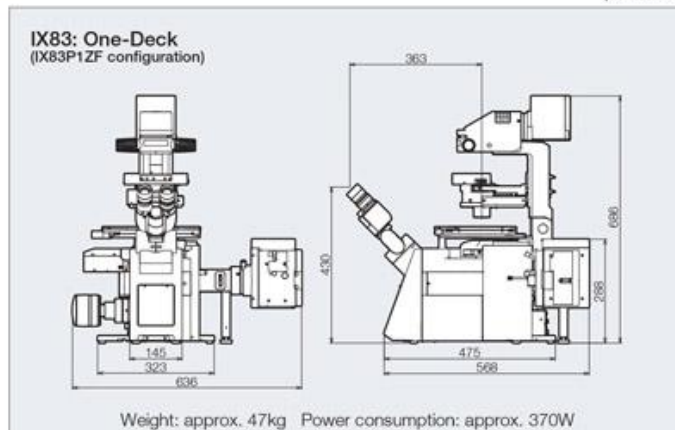
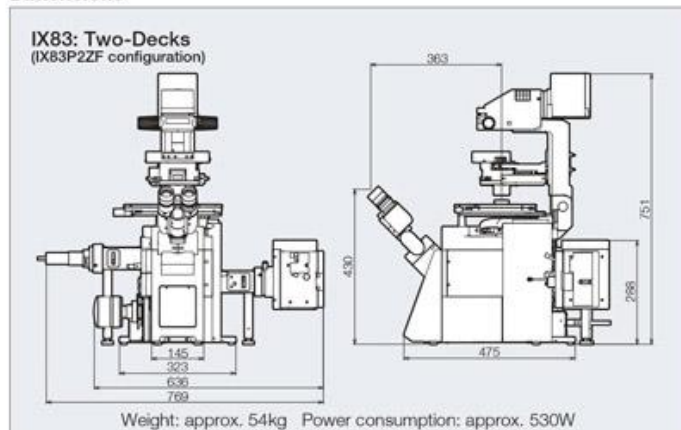

- OLYMPUS CORPORATION is ISO14001 certified.
- OLYMPUS CORPORATION is FM553994/ISO9001 certified.
- OLYMPUS CORPORATION is MD540624/ISO13485 certified.
- Illumination devices for microscope have suggested lifetimes. Periodic inspections are required. Please visit our website for details.
- All company and product names are registered trademarks and/or trademarks of their respective owners.
- Images on the PC monitors are simulated.
- Specifications and appearances are subject to change without any notice or obligation on the part of the manufacturer.

OLYMPUS

OLYMPUS CORPORATION
Shinjuku Monolith, 3-1, Nishi Shinjuku 2-chome, Shinjuku-ku, Tokyo, Japan
OLYMPUS EUROPA SE & CO. KG
Wendenstrasse 14-18, 20097 Hamburg, Germany
OLYMPUS AMERICA INC.
3500 Corporate Parkway, Center Valley, Pennsylvania 18034-0610, U.S.A.
OLYMPUS SINGAPORE PTE LTD.
491B River Valley Road, #12-01/04 Valley Point Office Tower, Singapore 248373
OLYMPUS AUSTRALIA PTY. LTD.
21 Gilby Road, Mt. Waverley, VIC 3149, Melbourne, Australia

OLYMPUS LATIN AMERICA, INC.
5301 Blue Lagoon Drive, Suite 230 Miami, FL 33126, U.S.A.
OLYMPUS (CHINA) CO., LTD.
ABF, Ping An International Financial Center, No. 1-3, Xinyuan South Road,
Chaoyang District, Beijing, China, 100027
OLYMPUS KOREA CO., LTD.
Olympus-Tower, 114-9 Samseong-Dong, Gangnam-Gu, Seoul, Korea

www.olympus.com

Printed in Japan M1756E-062013