

Cameras Area Scan Cameras Models Basler ace

# acA1920-155um

The acA1920-155um [Basler ace USB 3.0 camera](#) is equipped with a Sony IMX174 sensor.







## Specifications

### General Specifications

	acA1920-155um
Resolution (H x V Pixels)	1936 × 1216 (full resolution) 1920 × 1200 (default resolution)

	acA1920-155um
	You can change the resolution by changing the <a href="#">image ROI</a> .
Resolution	2.3 MP
Sensor Type	Sony IMX174LLJ-C Progressive scan CMOS <a href="#">Global shutter</a>
Sensor Format	1/1.2"
Effective Sensor Diagonal	13.4 mm
Pixel Size (H x V)	5.86 × 5.86 μm
Frame Rate (at Default Settings)	164 fps
Product Family	<a href="#">ace U</a> 
Mono / Color	Mono
Image Data Interface	USB 3.0, nominal max. 5 Gbit/s (SuperSpeed)
Pixel Formats	See <a href="#">Pixel Format</a> .

	acA1920-155um
Synchronization	Via hardware trigger Via software trigger Via free run
Exposure Time Control	Via hardware trigger Programmable via the camera API
Camera Power Requirements	≈3.2 W (typical) @ 5 VDC ≈3.5 W (max.)
I/O Lines	1 <a href="#">opto-coupled input line</a> 1 <a href="#">opto-coupled output line</a> 2 <a href="#">general purpose I/O (GPIO) lines</a>
Lens Mount	C-mount
Size (L x W x H)	29.3 × 29 × 29 mm (without lens mount or connectors) 48.2 × 29 × 29 mm (with lens mount and connectors)
Weight	<80 g
Conformity	CE (includes RoHS), EAC, UL Listed, FCC, GenICam 2.x (including PFNC 2.x and SFNC 2.x), IP30, USB3 Vision, REACH, KC

	acA1920-155um
	<a href="#">Certificates for your camera model</a>  For more information, see the <a href="#">Compliance</a>  section of the Basler website.
Software	<a href="#">Basler pylon Camera Software Suite</a>  (version 4.0 or higher) Available for Windows, Linux x86, Linux ARM, macOS, and Android
Accessories	<a href="#">Accessories for your camera model</a> 
Availability and Pricing	See the <a href="#">product page</a>  on the Basler website.

## Spectral Response

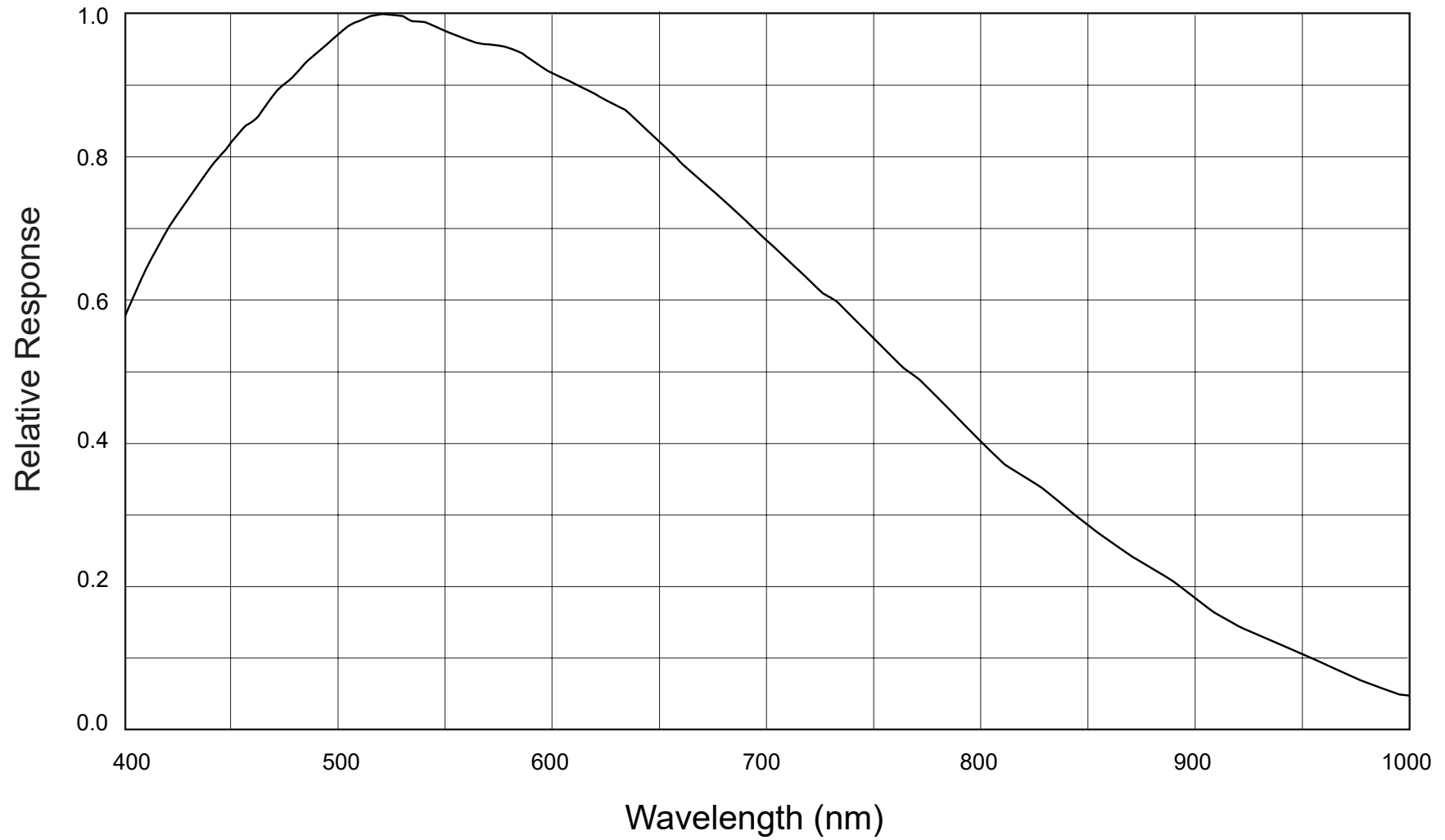

# Mechanical Specifications

## Camera Dimensions and Mounting Points

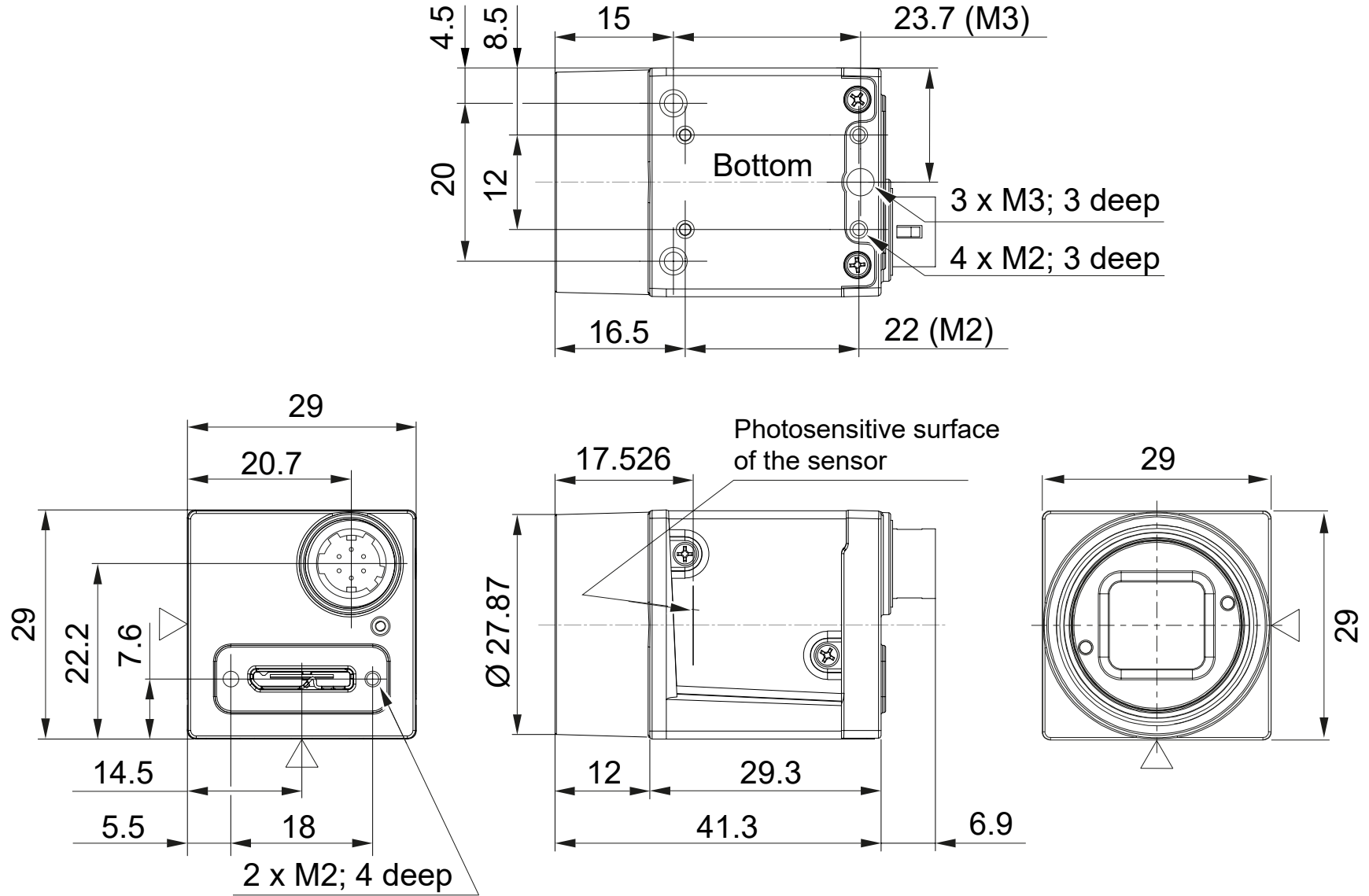

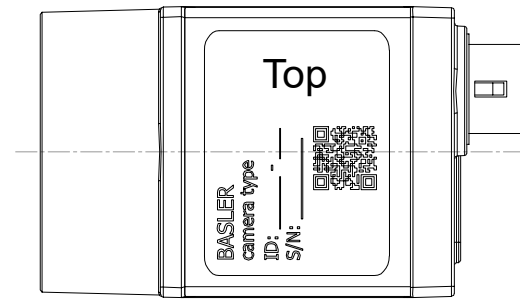

▷ Reference plane

Not to scale  
Dimensions in mm

→ Download the [CAD/technical drawing for your Basler camera](#) [↗](#).

## Maximum Allowed Lens Intrusion

→ See [Maximum Allowed Lens Intrusion](#).

## Mounting Instructions

→ See [Mounting Instructions](#).

## Stress Test Results

→ See [Stress Test Results](#).



# Requirements

## Environmental Requirements

### Temperature and Humidity

Housing temperature during operation	0–50 °C (32–122 °F)
Humidity during operation	20–80 %, relative, non-condensing
Storage temperature	-20–80 °C (-4–176 °F)
Storage humidity	20–80 %, relative, non-condensing
Housing temperature according to UL 60950-1	max. 70 °C (158 °F)
Ambient temperature according to UL 60950-1	max. 30 °C (86 °F)

### Heat Dissipation

→ See [Providing Heat Dissipation](#).

## Electrical Requirements

### **WARNING – Electric Shock Hazard**

Unapproved power supplies may cause electric shock. Serious injury or death may occur.

- You must use power supplies that meet the Safety Extra Low Voltage (SELV) and Limited Power Source (LPS) requirements.
- If you use a powered hub or powered switch, they must meet the SELV and LPS requirements.

### **WARNING – Fire Hazard**

Unapproved power supplies may cause fire and burns.

- You must use power supplies that meet the Limited Power Source (LPS) requirements.
- If you use a powered hub or powered switch, they must meet the LPS requirements.

### **NOTICE – Incorrect voltage can damage the camera.**

You must supply camera and I/O power within the safe operating voltage ranges specified below.

Do not use negative voltage for an I/O line.

## Camera Power

You must supply camera power that complies with the Universal Serial Bus 3.0 specification.

The camera's nominal operating voltage is 5 VDC, effective on the camera's connector.

## Opto-Coupled I/O Input Line

Voltage	Description
30 VDC	Absolute maximum. This voltage must never be exceeded. Doing so may damage the camera and voids the warranty.
0–24 VDC	Safe operating range.
0–1.4 VDC	Indicates a logical 0 (with inverter disabled).
>1.4–2.2 VDC	Region where the logic level transition occurs; the logical state is not defined in this region.
>2.2 VDC	Indicates a logical 1 (with inverter disabled).

- **Minimum current:** 5 mA
- **Current draw:** 5–15 mA
- If the camera is connected to a PLC device, Basler recommends using a cable that adjusts the voltage level of the PLC to that of the camera.

## Opto-Coupled I/O Output Line

Voltage	Description
30 VDC	Absolute maximum. This voltage must never be exceeded. Doing so may damage the camera and voids the warranty.
3.3–24 VDC	Safe operating range.
<3.3 VDC	Unreliable I/O output.

- **Leakage current:** <60  $\mu$ A. Actual leakage depends on operating temperature and production spread of electronic components.
- **Maximum load current:** 50 mA
- **Minimum load current:** Not specified. Consider the following:
  - Leakage current will have a stronger effect when load currents are low.
  - Propagation delay of the output increases as load currents decrease.
  - Higher-impedance circuits tend to be more susceptible to EMI.
  - Higher currents cause higher voltage drops in long cables.

## General Purpose I/O Lines

 **NOTICE: Applying incorrect electrical signals to the camera's GPIO line can severely damage the camera.** 

Before you connect any external circuitry to the GPIO line, use the [Line Mode](#) feature to configure the line for input or output.

Make sure to apply appropriate input or output signal voltages as specified below.

## Operation as Input

Voltage	Description
30 VDC	Absolute maximum. This voltage must never be exceeded. Doing so may damage the camera and voids the warranty.
0–5 VDC	Safe operating range. The minimum external pull-up voltage is 3.3 VDC.
0–0.8 VDC	Indicates a logical 0 (with inverter disabled).
>0.8–2.0 VDC	Region where the logic level transition occurs; the logical state is not defined in this region.
>2.0 VDC	Indicates a logical 1 (with inverter disabled).

- **Current draw (high-level):** <100  $\mu$ A
- **Sink current:** Your application must be able to accept 2 mA sink current from the GPIO input line without exceeding 0.8 VDC.

## Operation as Output

Voltage	Description
30 VDC	Absolute maximum. This voltage must never be exceeded. Doing so may damage the camera and voids the warranty.

Voltage	Description
3.3–24 VDC	Safe operating range.
<3.3 VDC	Unreliable I/O output.

- **Internal pull-up resistor:**  $\approx 2 \text{ k}\Omega$ , with open collector. Many applications will have to provide an additional pull-up resistor.
- **Residual voltage ("on" state):**  $\approx 0.4 \text{ VDC}$  at 50 mA and 25 °C (77 °F) housing temperature. Actual residual voltage depends on operating temperature, load current, and production spread of electronic components.
- **Leakage current:**  $< 60 \text{ }\mu\text{A}$ . Actual leakage depends on operating temperature and production spread of electronic components.
- **Maximum load current:** 50 mA
- **Minimum load current:** Not specified. Consider the following:
  - Leakage current will have a stronger effect when load currents are low.
  - Propagation delay of the output increases as load currents decrease.
  - Higher-impedance circuits tend to be more susceptible to EMI.
  - Higher currents cause higher voltage drops in long cables.

For more information about the I/O lines, see the [I/O Control](#) section.

## Circuit Diagrams

→ See [Circuit Diagrams](#).



## Cable Requirements

### USB 3.0 Cable

- Use a high-quality USB 3.0 cable with a Micro-B plug.
- To [avoid EMI](#), cables must be shielded, as specified in the USB 3.0 standard.
- Basler recommends using USB 3.0 cables from the [Basler cable portfolio](#) .

For more information about recommended USB 3.0 cables, see the [Recommended Accessories for Basler USB 3.0 Cameras](#)  document.

### I/O Cable

- The I/O cable must be shielded.
- The I/O cable must have a cross-section of at least 0.14 mm<sup>2</sup> (close to AWG26).
- Use twisted pair wire cables.
- Maximum recommended cable length: 10 m
- Camera-side connector: Hirose micro plug (part number HR10A-7P-6S) or equivalent
- Proximity to strong magnetic fields should be avoided.
- Basler recommends using I/O cables from the [Basler cable portfolio](#) :
  - [GPIO cable, 10 m](#)  (yellow cable): For use with the [GPIO lines](#) of your camera. To avoid interferences due to crosstalk, the opto-coupled I/O lines are not connected.
  - [Opto-I/O cable, 10 m](#)  (blue cable): For use with the [opto-coupled I/O lines](#) of your camera. To avoid interferences due to crosstalk, the GPIO lines are not connected.

- [Opto-GPIO Y-cable, 2 × 10 m](#) (yellow-blue cable): Allows you to use the [GPIO lines](#) and the [opto-coupled I/O lines](#) simultaneously without interferences due to crosstalk. There are two separate wires to split both I/O types.
- [Power-I/O PLC+ cable, 10 m](#) (gray cable): For use with the [opto-coupled I/O lines](#) of Basler cameras connected to a programmable logic controller ([PLC](#)). It adapts the signal level for zero voltage from PLC level (<8.4 VDC) to TTL level (<1.4 VDC).

## Physical Interface

### Camera Connectors and Status LED

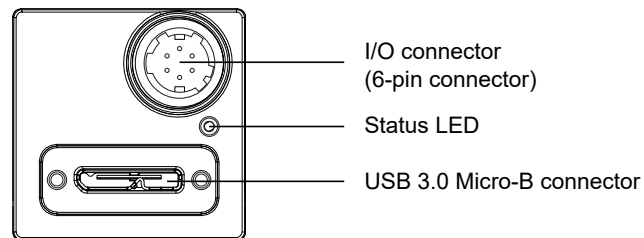

### I/O Connector

- Hirose micro receptacle (part number HR10A-7R-6PB)
- Recommended mating connector: Hirose micro plug (part number HR10A-7P-6S)

### USB 3.0 Micro-B Connector



- Standard USB 3.0 Micro-B connector with screw lock
- Recommended mating connector: Standard USB 3.0 Micro-B connector with screws

## Status LED

Indicates camera operation (LED lit = camera operating).

## Connector Pinout

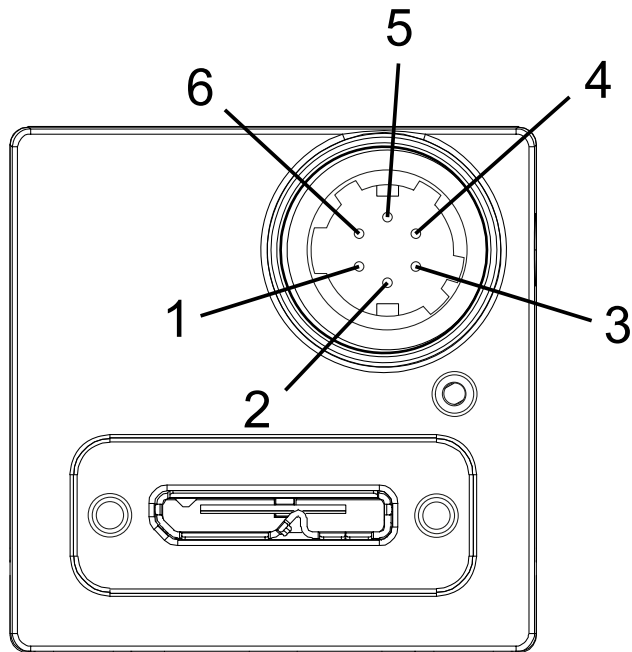

Pin	Line	Function
1	Line 3	General purpose I/O (GPIO) line
2	Line 1	Opto-coupled I/O input line
3	Line 4	General purpose I/O (GPIO) line
4	Line 2	Opto-coupled I/O output line
5	-	Ground for opto-coupled I/O lines
6	-	Ground for General Purpose I/O (GPIO) lines

## Precautions

→ See [Safety Instructions \(ace, ace 2\)](#).

## Installation

→ See [Camera Installation](#).

# Features

→ See [Features](#).